

Application Note AN-1 Using the ETX-2 & ETX-4 Pulsed Laser Diode Drivers

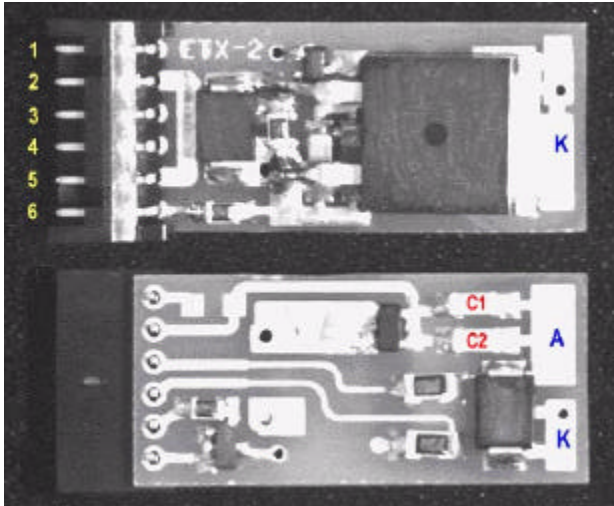

INTERFACE:

connector

- ① TRIGGER INPUT
- ② COMMON
- ③ +HV BIAS (320Vdc)
- ④ +HV LASER
- ⑤ COMMON
- ⑥ DISCHARGE MONITOR OUT

laser connection

- A - Anode
- K - Cathode

Simple test circuit:

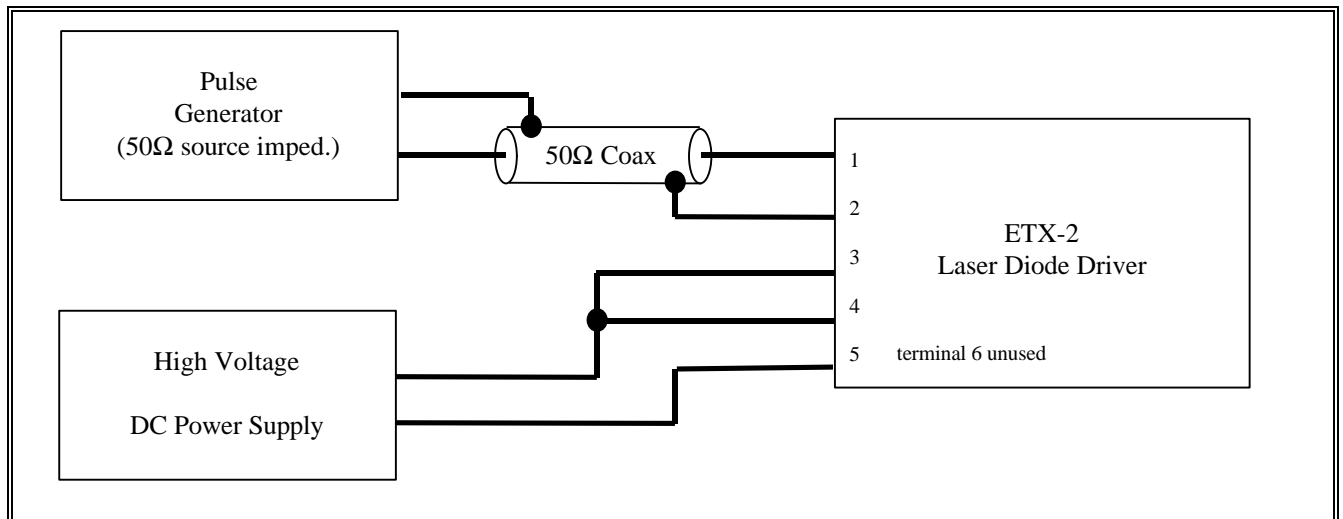

Test Parameters

Load: attach appropriate laser diode or use dummy load by shorting A-K with wire < 1" in length. Eye-safety procedures should be strictly enforced with exposed laser diodes.

Pulse Generator: to improve eye-safety, set pulse rate as low as possible if a laser is used. If a dummy load is used, do not set pulse rate higher than maximum specification. Pulse should be positive, TTL compatible, width 20 ns - 1 μs

Single Power Supply: When connecting a single supply to test the driver, parallel the supply input terminals 3 and 4. The power supply should be adjusted to nominally 320 Vdc (300 - 330Vdc). Current consumption will depend upon pulse rate but is typically 2mA - 5mA.

Dual Power Supplies: Use of two power supplies allows for independent connection to terminals 3 and 4. In this way, the voltage present at terminal 4 can be varied from 0 - 400Vdc (up to 500Vdc for the ETX-2) to control the laser discharge voltage (and consequently, peak current through the laser diode). Terminal 3 should always remain biased at 320 Vdc.

Measurement: The discharge voltage is easily monitored at the laser (or dummy load) cathode connection. A combination of wideband oscilloscope and probe with short (local) ground lead is recommended for this measurement. Alternatively, current through the load can be directly monitored with a wideband current probe attached to one lead of the laser diode or to the dummy load. This may, however, slow the measured risetime of the current through the load.

Peak Current Estimation

The peak discharge current is related primarily to three controllable factors: discharge voltage, discharge capacitance, and laser package inductance.

Discharge Voltage is the potential at terminal 4. It may be varied over the range of 0 to 400 Vdc (500Vdc for ETX-2).

Discharge Capacitance is determined by C1 and C2. A stock ETX-2 is shipped with two 1000pF (500V or greater), low-ESR, low-inductance, multilayer X7R ceramic capacitors in a type 1206 SMD package.

Laser Package Inductance is chosen to be a minimum and its value has an increasing impact on the risetime of the current pulse as larger package inductances are implemented.

By integrating and linearizing the equation for current through a capacitor vs. time a simple expression to determine *best case* peak current can be illustrated as:

$$C_{dis} V_{dis} = I_{load} t_{dis}$$

For a stock ETX-2 with 320V bias and discharge voltage with a measured discharge time of 20 nanoseconds (90% - 10% discharge voltage at the cathode connection), the maximum estimated peak current through the load would be:

$$I_{load} = (2nF)(320V) / (20nS) = 32 \text{ Amps(pk)}$$

The actual value of peak current will be less due to voltage drop across the load, capacitors, and all components in the discharge loop including the MOSFET switch. Each has its own ESR and inductance which cause a dynamically changing voltage drop as the discharge progresses. This effectively reduces the amount of V_{dis} available to generate a high peak current.

The peak voltage drop across a discharge loop component may be approximated as:

$$V_{\text{drop}} = (L_{\text{pkg}})(I_{\text{pk}}) / (t_{\text{dis}}) + (I_{\text{pk}})(R_{\text{ESR}})$$

The voltage discharge time is closely related to the current pulse width and are often referred to interchangeably. A stock ETX-2 will typically produce a 20 nS pulse width at 320V discharge with a short dummy load. The discharge time is primarily dependent upon the discharge capacitance (C1 and C2), loop inductance and ESR, and the dynamic switching profile of the MOSFET Rds(on) during the discharge. It is also effected by the discharge voltage due to MOSFET switching characteristics. Higher voltages not only increase peak current, pulse width and risetime, they reduce the propagation delay from trigger to discharge. For this reason terminal 6 (discharge monitor output) is provided for temperature and voltage sensitive applications which demand nanosecond accurate measurements of laser pulse propagation such as OTDR's and laser rangefinders.

The table below approximates expected pulse widths for an ETX-2 with a short circuit load for different discharge capacitances (C1 + C2) with a 320V discharge potential:

discharge capacitance (C1 + C2)	approximate pulse width
470pF	7 ns
940pF (2 x 470pF)	11 ns
1470pF (470pF + 1000pF)	16 ns
2000pF (2 x 1000pF)	20 ns

Precautions and Design Considerations

For many metal laser diode packages, the case is electrically connected to the discharge voltage (from terminal 4). This requires careful design consideration to isolate the laser package from the surrounding environment which is often grounded. This also presents an electrical shock hazard if handling the laser and driver is necessary during open bench testing.

The ETX-2 may be mechanically mounted only through the rigidity of the laser leads. Alternatively, the MOSFET plastic package can be used as a pedestal for a more strain relieved attachment of the driver to its surroundings. This may be achieved by gluing the MOSFET face to a material which would ideally be metal to enhance the heatsinking ability of the driver.

Many pulsed laser diodes are capable of tremendous peak optical power output and accordingly demand the practice of eye-safe procedures. This is especially true when the laser is removed from an apparatus such that the bare laser diode is visible. The optical power density near the device can be very hazardous to the eye.